

**GYPROCK®**

Everything else is just plasterboard

# Glasroc F

High performance fire protection for structural steel columns and beams

# Introducing Gyprock® Glasroc F

Gyprock Glasroc F is a 30mm thick, high density, square edged gypsum board. It is recommended for multi-residential and commercial construction projects where a fire rated encasement is required for structural steel beams and columns to provide fire protection of up to FRL 120/-/-.

The frameless encasement system is suitable for protecting structural steel members with a section factor  $H_p/A$  up to  $260m^{-1}$ , calculated on the box protection of all exposed sides. It will protect universal column and beam sections, other re-entrant sections such as channels and angles, and hollow sections.

Glasroc F contains glass tissue immediately below the surface of the board and glass fibre rovings throughout the core, giving an excellent surface finish, good impact resistance and moisture tolerance in partially exposed situations.

Installation is quick and simple with Glasroc F boards screw-fixed to one another without the need for additional framing, adhesive or fillers. Jointing and the application of decorative treatments are not required for a smooth, robust surface or to ensure the fire protection performance of the encasement system, but should be considered in spaces where aesthetics are important.

Glasroc F was developed by worldwide plasterboard specialist Saint-Gobain and forms part of Gyprock's International Alliance program. The program is aimed at developing exclusive relationships with leading manufacturers to deliver the best products to the Australian market.





### Key benefits

- High levels of fire protection to structural steelwork
- Board manufactured to tight thickness tolerances
- Single-layer installation to minimise space used
- Fast to install – boards are screw-fixed to one another without the need for framing, adhesive or fillers
- No finishing required to achieve the fire performance
- Moisture tolerance means it can be installed early in the build programme
- Minimal impact to other trades on site
- Easy to inspect for continuity meaning greater peace of mind after installation and during maintenance
- Provides a smooth, impact resistant surface
- Tested to international standard EN 1338-4:2013 and assessed to AS 4100 1998 AMD 1-2013 Steel Structures

# Performance Properties

Glasroc F provides fire protection to columns and beams due to its unique behaviour when exposed to fire. The board's gypsum content contains nearly 21% chemically combined water or crystallisation, and about 79% calcium sulphate. When Glasroc F is exposed to fire, the chemically combined water is gradually released in the form of water vapour. This is the process of calcination which commences at the surface exposed to the fire and proceeds gradually through the board thickness. This process becomes progressively slower as the thickness of calcined material increases and means that the unexposed side of the board does not exceed 100°C for a prolonged period of time. Once the gypsum layer is completely calcined, the calcium sulphate continues to act as an insulating layer for as long as it remains intact.

The graph below shows the temperature profile on the unexposed face of a Glasroc F lined encasement system. During the process of calcination, there is a large plateau in the temperature rise, particularly over the initial 120 minutes.

Temperature profile of Glasroc F

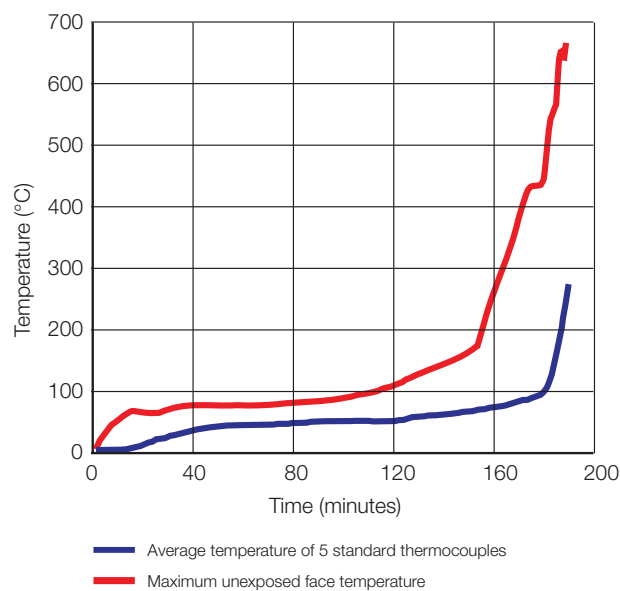

# Section Factors A/V and Hp/A

The rate of increase in temperature of a steel cross-section is determined by the ratio of the heated surface area (A) to the contained steel volume (V). This is expressed as either A/V, or without considering the length dimension, as Hp/A, the Heated Perimeter to cross sectional area. For convenience, the latter is used here although they have the same value. This ratio has units of m<sup>-1</sup> and is known as the Section Factor. Steel members with a low Section Factor will heat up at a slower rate compared to one with a high Section Factor, and low Section Factors are associated with large member sizes.

A steel section with a large exposed surface area will receive more heat than one with a smaller surface area. Also, the greater the volume of the section, the longer it will take to heat up. It follows that a large thick-walled section will be slower to increase in temperature than a small thin-walled one. The Section Factor is thus a measure of the rate at which a section will heat up in a fire. A lower value of Section Factor means that a higher fire rating is provided by the protective board thickness.

This diagram illustrates how steel sections with a low Section Factor will heat up at a slower rate compared to sections with a large surface area.

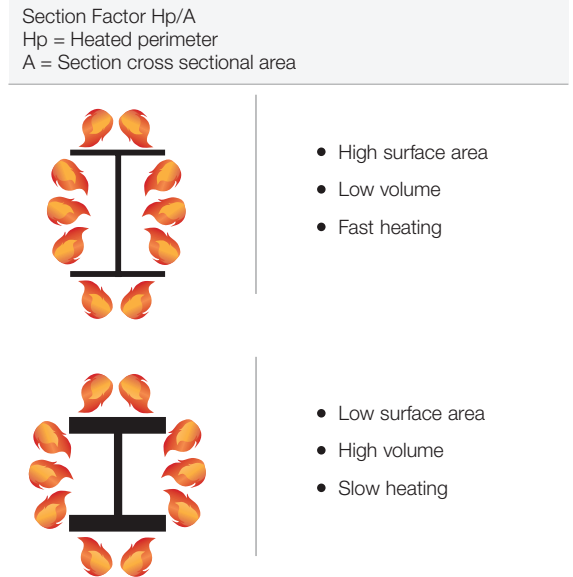

Source: Adapted from ASFP document 'Fire protection for structural steel in buildings – 4<sup>th</sup> edition'.

## FRL calculation

Glasroc F is the subject of BRANZ Fire Assessment Report FAR 4876 to provide fire resistance for steel columns and beams in accordance with AS 4100. For a specific steel member, the following process may be used to determine the Structural Adequacy component of Fire Resistance Level provided by 30mm Glasroc F:

1. Calculate Hp, the exposed perimeter of the member. For columns, sides adjacent to concrete or masonry walls having the required FRL are not included. For beams supporting a concrete slab, the top surface is not included. Typical cases are given in Table 1.
2. Use the member cross sectional area A from the supplier's section property data to calculate Hp/A. Some typical section properties are given in Table 2
3. Determine T<sub>i</sub>, the limiting steel temperature to be used, in accordance with AS 4100 Clause 12.5.

$$T_i = 905 - 690r_f$$

Where r<sub>f</sub> is the ratio of design action on the member under the design load for fire (AS/NZS 1170.0), to the design capacity of the member. This can usually be taken as 550°C for columns and 620°C for beams.

4. Refer to Chart 1 for columns and Chart 2 for beams. For the limiting temperature (round down to the next lowest value) compare the calculated member Hp/A value to the maximum Hp/A tabulated for the required fire rating. If it is equal to or lower than the chart value, then the structural adequacy component of the FRL is confirmed. Otherwise choose a section with a lower Hp/A value and re-check.

**Chart 1: Columns**

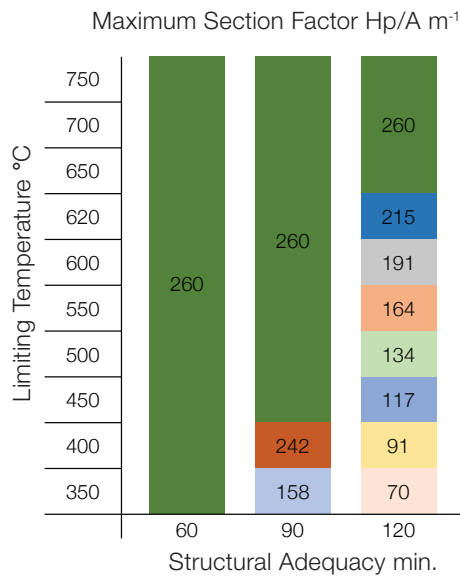

**Chart 2: Beams**

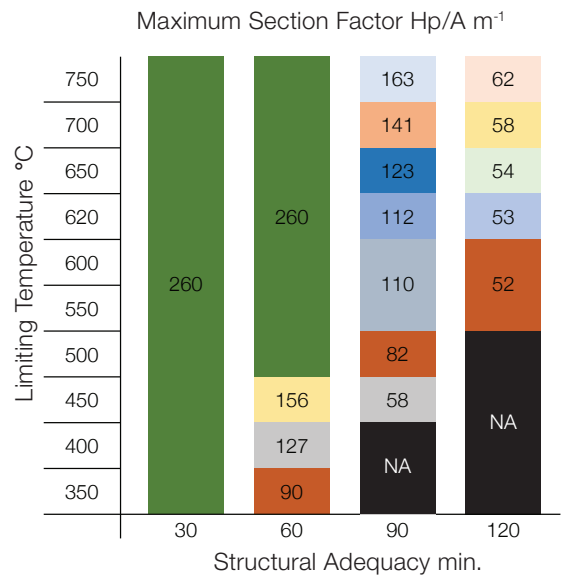

**Example Calculation**

A column supporting a floor slab is required to have FRL 120/-/- . A 125x75x3.0 RHS is proposed and will abut a concrete wall that protects one long side of the column.

RHS Section	Gross Section Area mm <sup>2</sup>
125x75x6	2155
125x75x3	1148

For the Section Factor:

$$H_p = (0.125 + 0.75 + 0.75) = 0.275\text{m}$$

$$A = 1148 \times 10^{-6} \text{m}^2$$

$$H_p/A = 240 \text{m}^{-1}$$

The load action ratio  $r_f$  has been calculated as 0.5. The limiting steel temperature is then:

$$T_i = 905 - 690 \times 0.5 = 560^\circ\text{C}$$

From the row for the next lowest temperature  $T_i = 550$ , the maximum  $H_p/A$  for 120 rating is 164.

The rating is not achieved as the calculated  $H_p/A$  must be less than or equal to chart value.

For a 125x75x6.0 RHS with  $r_f = 0.5$ :

$$H_p = (0.125 + 0.75 + 0.75) = 0.275\text{m}$$

$$A = 2155 \times 10^{-6} \text{m}^2$$

$$H_p/A = 128 \text{m}^{-1}$$





As this is lower than 164 the 120/-/- FRL is achieved.

**Values for  $H_p$  and  $A$**

In calculating the Section Factor value, the full cross sectional ( $A$ ) is used for any number of exposed sides, as the whole of the steel section will be receiving heat. The Heated Perimeter ( $H_p$ ) is taken as the sum of the inside dimensions of the smallest possible rectangular or square encasement. The value of  $H_p$  is the sum of the exposed sides and depends on the configuration of the fire protection.

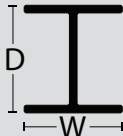
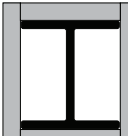
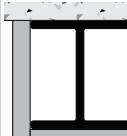
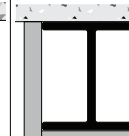

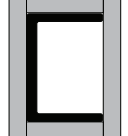
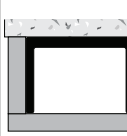
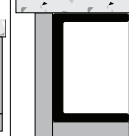
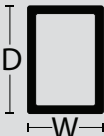
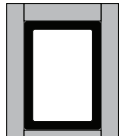
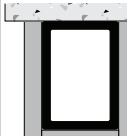
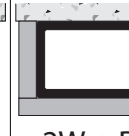
Typical values for Heated Perimeter Hp

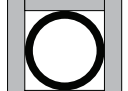
Steel profile	Surface Area		
<b>Universal Beam/Column</b>			
	4 sides	3 sides	2 sides
	 $2W + 2D$	 $W + 2D$	 $W + D$
<b>Channels</b>			
	4 sides	3 sides	3 sides
	 $2W + 2D$	 $2W + D$	 $W + 2D$
<b>Square / Rectangle Hollow Section</b>			
	4 sides	3 sides	3 sides
	 $2W + 2D$	 $W + 2D$	 $2W + D$
<b>Circular Hollow Section</b>			
	4 sides		
	 $4D$		





# Steel Section Properties

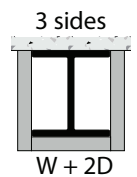
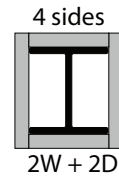
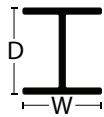

Universal Beams Grade 300PLUS®						
Designation	Depth of Section D (mm)	Width of Section W (mm)	Gross Area of Cross Section (mm <sup>2</sup> )	Mass (kg/m)	A/V (Hp/A) 4 sides 2W + 2D (m <sup>-1</sup> )	A/V (Hp/A) 3 sides W + 2D (m <sup>-1</sup> )
610UB125	612	229	16000	125	105	91
610UB113	607	228	14500	113	115	99
610UB101	602	228	13000	101	128	110
530UB92.4	533	209	11800	92.4	126	108
530UB82	528	209	10500	82	140	120
460UB82.1	460	191	10500	82.1	124	106
460UB74.6	457	190	9520	74.6	136	116
460UB67.1	454	190	8580	67.1	150	128
410UB59.7	406	178	7640	59.7	153	130
460UB53.7	403	178	6890	53.7	169	143
360UB56.7	359	172	7240	56.7	147	123
360UB50.7	356	171	6470	50.7	163	136
360UB44.7	352	171	5720	44.7	183	153
310UB46.2	307	166	5930	46.2	160	132
310UB40.4	304	165	5210	40.4	180	148
310UB32	298	149	4080	32	219	183
250UB37.3	256	146	4750	37.3	169	139
250UB31.4	252	146	4010	31.4	199	162
250UB25.7	248	124	3270	25.7	228	190
200UB29.8	207	134	3820	29.8	179	143
200UB25.4	203	133	3230	25.4	208	167
200UB22.3	202	133	2870	22.3	233	187
200UB18.2	198	99	2320	18.2	256	213
180UB22.2	179	90	2820	22.2	191	159
180UB18.1	175	90	2300	18.1	230	191
180UB16.1	173	90	2040	16.1	258	214
150UB18	155	75	2300	18	200	167
150UB14	150	75	1780	14	253	211

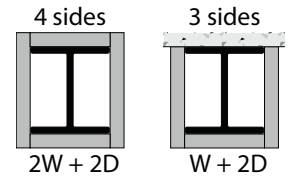
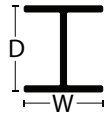

Universal Columns Grade 300PLUS®						
Designation	Depth of Section D (mm)	Width of Section W (mm)	Gross Area of Cross Section (mm <sup>2</sup> )	Mass (kg/m)	A/V (Hp/A) 4 sides 2W + 2D (m <sup>-1</sup> )	A/V (Hp/A) 3 sides W + 2D (m <sup>-1</sup> )
310UC158	327	311	20100	158	63	48
310UC137	321	309	17500	137	72	54
310UC118	315	307	15000	118	83	62
310UC96.8	308	305	12400	96.8	99	74
250UC89.5	260	256	11400	89.5	91	68
250UC72.9	254	254	9320	72.9	109	82
200UC59.5	210	205	7620	59.5	109	82
200UC52.2	206	204	6660	52.2	123	92
200UC46.2	203	203	5900	46.2	138	103
150UC37.2	162	154	4730	37.2	134	101
150UC30	158	153	3860	30	161	122
150UC23.4	152	152	2980	23.4	204	153
100UC14.8	97	99	1890	14.8	207	155

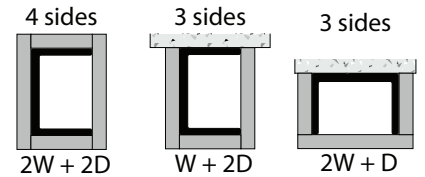
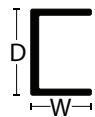

Parallel Flange Channels Grade 300PLUS®							
Designation	Depth of Section D (mm)	Width of Section W (mm)	Gross Area of Cross Section (mm <sup>2</sup> )	Mass (kg/m)	A/V (Hp/A) 4 sides 2W + 2D (m <sup>-1</sup> )	A/V (Hp/A) 3 sides W + 2D (m <sup>-1</sup> )	A/V (Hp/A) 3 sides (2W + D) (m <sup>-1</sup> )
380PFC55.2	380	100	7030	55.2	137	122	83
300PFC40.1	300	90	5110	40.1	153	135	94
250PFC35.5	250	90	4520	35.5	150	131	95
230PFC25.1	230	75	3200	25.1	191	167	119
200PFC22.9	200	75	2920	22.9	188	163	120
180PFC20.9	180	75	2660	20.9	192	164	124
150PFC17.7	150	75	2250	17.7	200	167	133
125PFC11.9	125	65	1520	11.9	250	207	168
100PFC8.33	100	50	1060	8.33	283	236	189
75PFC5.92	75	40	754	5.92	305	252	206

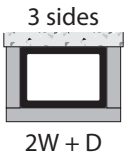
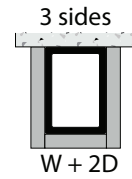
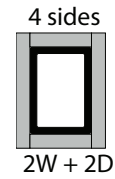
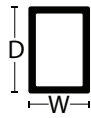

Rectangular Hollow Sections grade 450PLUS®							
Designation	Depth of Section D (mm)	Width of Section W (mm)	Gross Area of Cross Section (mm <sup>2</sup> )	Mass (kg/m)	A/V (Hp/A) 4 sides 2W + 2D (m <sup>-1</sup> )	A/V (Hp/A) 3 sides W + 2D (m <sup>-1</sup> )	A/V (Hp/A) 3 sides D + 2W (m <sup>-1</sup> )
250x150x12.5 RHS	250	150	8840	69.4	90	74	62
250x150x10 RHS	250	150	7260	57	110	90	76
250x150x9 RHS	250	150	6600	51.8	121	98	83
250x150x8 RHS	250	150	5920	46.5	135	110	93
250x150x6 RHS	250	150	4530	35.6	177	143	121
250x150x5 RHS	250	150	3810	29.9	210	171	144
200x100x10 RHS	200	100	5260	41.3	114	95	76
200x100x9 RHS	200	100	4800	37.7	125	104	83
200x100x8 RHS	200	100	4320	33.9	139	116	93
200x100x6 RHS	200	100	3330	26.2	180	150	120
200x100x5 RHS	200	100	2810	22.1	214	178	142
200x100x4 RHS	200	100	2280	17.9	263	219	175
152x76x6 RHS	152	76	2470	19.4	185	154	123
152x76x5 RHS	152	76	2090	16.4	218	182	145
150x100x10 RHS	150	100	4260	33.4	117	94	82
150x100x9 RHS	150	100	3900	30.6	128	103	90
150x100x8 RHS	150	100	3520	27.7	142	114	99
150x100x6 RHS	150	100	2730	21.4	183	147	128
150x100x5 RHS	150	100	2310	18.2	216	173	152
150x100x4 RHS	150	100	1880	14.8	266	213	186
125x75x6 RHS	125	75	2130	16.7	188	153	129
125x75x5 RHS	125	75	1810	14.2	221	180	152
125x75x4 RHS	125	75	1480	11.6	270	220	186
125x75x3 RHS	125	75	1140	8.96	351	285	241
125x75x2.5 RHS	125	75	959	7.53	417	339	287
125x75x2 RHS	125	75	774	6.07	517	420	355
102x76x6 RHS	102	76	1870	14.7	190	150	136
102x76x5 RHS	102	76	1590	12.5	224	176	160
102x76x3.5 RHS	102	76	1150	9.07	310	243	221

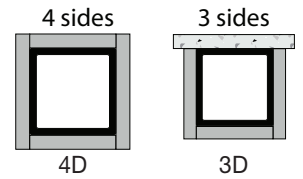
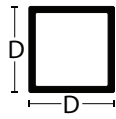

Square Hollow Sections grade 450PLUS®						
Designation	Depth of Section D (mm)	Width of Section W (mm)	Gross Area of Cross Section (mm <sup>2</sup> )	Mass (kg/m)	A/V (Hp/A) 4 sides 4D (m <sup>-1</sup> )	A/V (Hp/A) 3 sides 3D (m <sup>-1</sup> )
250x250x16 SHS	250	250	14100	111	71	53
250x250x12.5 SHS	250	250	11300	89	88	66
250x250x10 SHS	250	250	9260	72.7	108	81
250x250x9 SHS	250	250	8400	65.9	119	89
250x250x8 SHS	250	250	7520	59.1	133	100
250x250x6 SHS	250	250	5730	45	175	131
200x200x16 SHS	200	200	10900	85.5	73	55
200x200x12.5 SHS	200	200	8840	69.4	90	68
200x200x10 SHS	200	200	7260	57	110	83
200x200x9 SHS	200	200	6600	51.8	121	91
200x200x8 SHS	200	200	5920	46.5	135	101
200x200x6 SHS	200	200	4530	35.6	177	132
200x200x5 SHS	200	200	3810	29.9	210	157
150x150x10 SHS	150	150	5260	41.3	114	86
150x150x9 SHS	150	150	4800	37.7	125	94
150x150x8 SHS	150	150	4320	33.9	139	104
150x150x6 SHS	150	150	3330	26.2	180	135
150x150x5 SHS	150	150	2810	22.1	214	160
125x125x10 SHS	125	125	4260	33.4	117	88
125x125x9 SHS	125	125	3900	30.6	128	96
125x125x8 SHS	125	125	3520	27.7	142	107
125x125x6 SHS	125	125	2730	21.4	183	137
125x125x5 SHS	125	125	2310	18.2	216	162
125x125x4S HS	125	125	1880	14.8	266	199
100x100x10 SHS	100	100	3260	25.6	123	92
100x100x9 SHS	100	100	3000	23.5	133	100
100x100x8 SHS	100	100	2720	21.4	147	110
100x100x6 SHS	100	100	2130	16.7	188	141
100x100x5 SHS	100	100	1810	14.2	221	166
100x100x4 SHS	100	100	1480	11.6	270	203
100x100x3 SHS	100	100	1140	8.96	351	263
100x100x2.5 SHS	100	100	959	7.53	417	313
100x100x2 SHS	100	100	774	6.07	517	388



4 sides

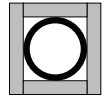

4D

Circular Hollow Sections grade C350LO				
Designation	Depth of Section D (mm)	Gross Area of Cross Section (mm <sup>2</sup> )	Mass (kg/m)	A/V (Hp/A) 4 sides 4D (m <sup>-1</sup> )
508x12.7 CHS	508	19800	155	103
508x9.5 CHS	508	14900	117	136
508x6.4 CHS	508	10100	79.2	201
457x12.7 CHS	457	17700	139	103
457x9.5 CHS	457	13400	105	136
457x6.4 CHS	457	9060	71.1	202
406.4x12.7 CHS	406.4	15700	123	104
406.4x9.5 CHS	406.4	11800	93	138
406.4x6.4 CHS	406.4	8040	63.1	202
355.6x12.7 CHS	355.6	13700	107	104
355.6x9.5 CHS	355.6	10300	81.1	138
355.6x6.4 CHS	355.6	7020	55.1	203
323.9x12.7 CHS	323.9	12400	97.5	104
323.9x9.5 CHS	323.9	9380	73.7	138
323.9x6.4 CHS	323.9	6380	50.1	203
273.1x12.7 CHS	273.1	10400	81.6	105
273.1x9.3 CHS	273.1	7710	60.5	142
273.1x6.4 CHS	273.1	5360	42.1	204
273.1x4.8 CHS	273.1	4050	31.8	270
219.1x8.2 CHS	219.1	5430	42.6	161
219.1x6.4 CHS	219.1	4280	33.6	205
219.1x4.8 CHS	219.1	3230	25.4	271
168.3x7.1 CHS	168.3	3600	28.2	187
168.3x6.4 CHS	168.3	3260	25.6	207
168.3x4.8 CHS	168.3	2470	19.4	273
165.1x3.5 CHS	165.1	1780	13.9	371
165.1x3 CHS	165.1	1530	12	432
139.7x3.5 CHS	139.7	1500	11.8	373
139.7x3 CHS	139.7	1290	10.1	433
114.3x3.6 CHS	114.3	1250	9.83	366
114.3x3.2 CHS	114.3	1120	8.77	408
101.6x3.2 CHS	101.6	989	7.77	411
101.6x2.6 CHS	101.6	809	6.35	502
88.9x3.2 CHS	88.9	862	6.76	413
88.9x2.6 CHS	88.9	705	5.53	504

Sources: OneSteel Manufacturing Pty Limited (ABN 42 004 651 325), a division of Liberty Steel. Hot Rolled and Structural Steel Products, 7th Ed. April 2014. Grade 300PLUS® Austube Mills Pty Ltd (ABN 21 123 666 679). Product Manual: Pipe & Tube June 2016. SHS & RHS grade C450PLUS, CHS grade C350LO



# Key Installation Requirements

Installation guidance must be closely adhered to in order to maintain the fire rating of the system in which Glasroc F is installed. Detailed installation information is available in the Gyprock Commercial Installation Guide at [Gyprock.com.au/resources](http://Gyprock.com.au/resources).

## In general:

- Glasroc F requires the use of specialised corrosion resistant self-tapping steel screws to maintain the fire rating. Available in 40 and 70mm lengths, these countersunk Phillips Head screws have a unique thread for the Glasroc F panels.
- Back block all joints that are not in direct contact with the steel column.
- Partitions and wall linings may be fixed directly to the Glasroc F board. If a wall has a fire rating greater than 60 minutes, additional framing is required.
- Caulking is only required where there are gaps greater than 3mm.
- Setting of joints is not required to maintain fire rating, however if a level 4 finish is required, the system should be finished in accordance with the Jointing and Finishing section of the Gyprock Commercial Installation Guide.



# Installation Details

The following diagrams cover the most common installation situations for column and beam encasement using Glasroc F. For a more comprehensive set of details, please consult the Gyprock Commercial Installation Guide, available at [gyprock.com.au/resources](http://gyprock.com.au/resources).

### 3 Sided Beam Encasement

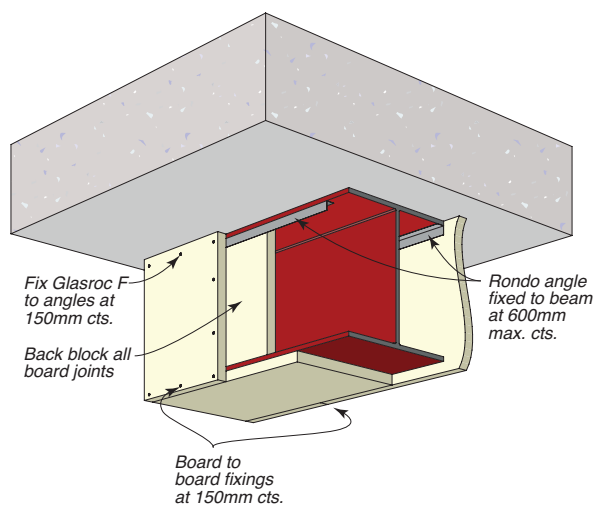

### 4 Sided Column Encasement

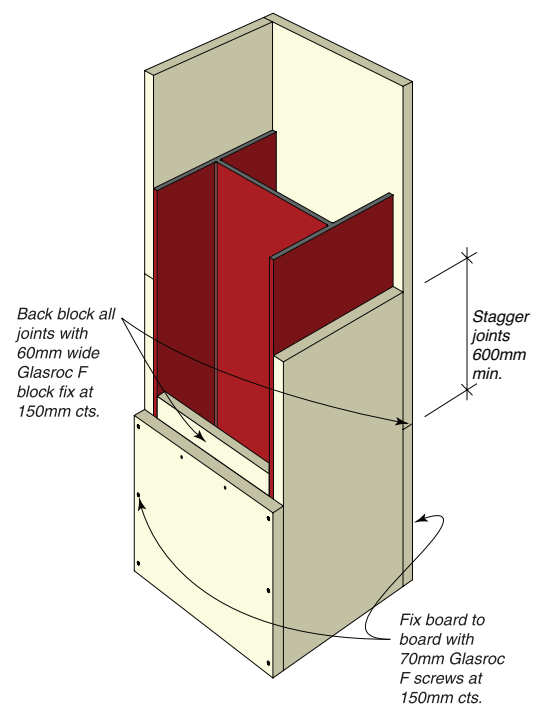



3 Sided Column Encasement

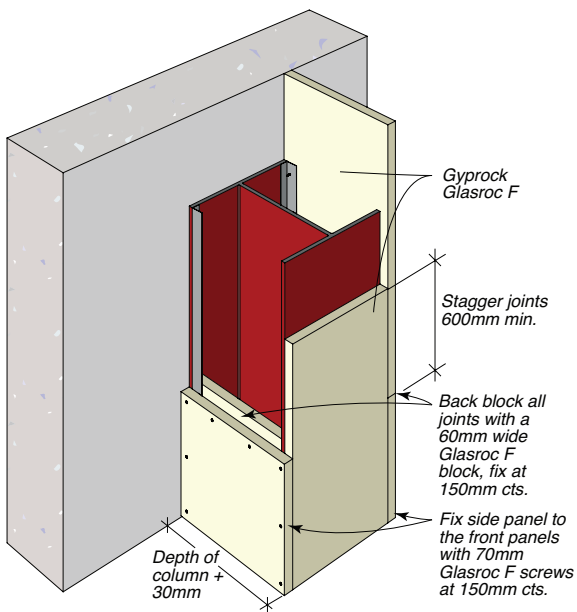

Column and Beam Encasement Junction

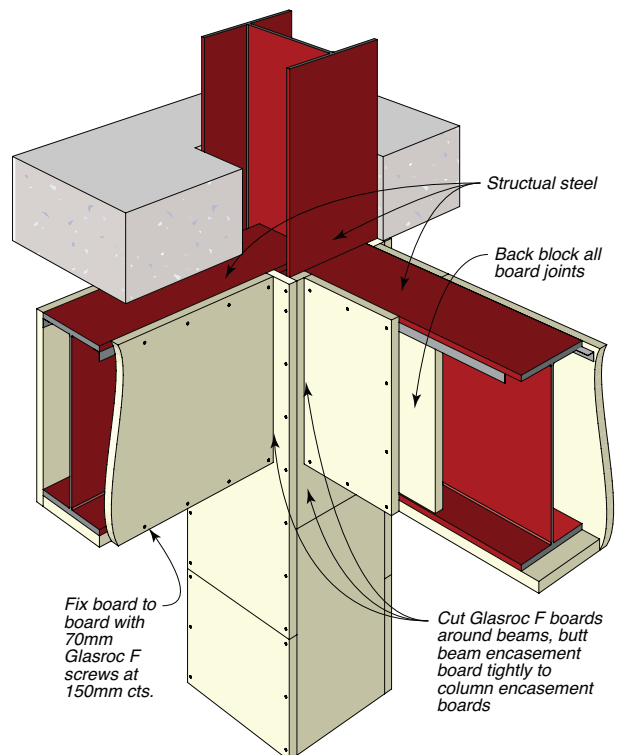

### Fire testing

Glasroc F has been tested to EN 1338- 4:2013 and assessed to AS 4100 1998 Amd 1-2013 Steel Structures. For more information about CSR Gyprock test data, please contact DesignLINK.

### Warranty

Gyprock products are designed to achieve optimal performance when part of a CSR integrated system.

CSR Building Products Limited warrants its Australian made Gyprock products to remain free of defects in material and manufacture for the usual lifetime of the product (25 years). CSR warrants its International Alliance Gyprock products to remain free of defects in material and manufacture for 7 years.

For details on our product warranty, please visit [gyprock.com.au](http://gyprock.com.au), or contact us on 1300 306 556.

### DesignLINK™

CSR DesignLINK has been established to help architects, engineers and other design professionals select the right products and systems for their projects. With extensive knowledge of the building industry, DesignLINK partners with clients to workshop complex design issues, provide value engineering, rationalise system specifications and deliver better building performance while maintaining build-ability for both builders and contractors. The dedicated phone number for DesignLINK Technical Support is 1800 621 117.



# GYPROCK®

Everything else is just plasterboard

For more information  
about Gyprock® Glasroc F,  
call 1300 306 556 or  
visit [gyprock.com.au](http://gyprock.com.au)

Triniti 3, 39 Delhi Road, North Ryde, NSW 2113, Australia  
CSR Building Products ABN 55 008 631 356

